

Engineering Specification

Job Name _____

Contractor _____

Job Location _____

Approval _____

Engineer _____

Contractor's P.O. No. _____

Approval _____

Representative _____

LEAD FREE*

MasterSeries® LF860

Reduced Pressure Zone Assembly

2½" – 10"

MasterSeries LF860 Reduced Pressure Zone assembly is designed to protect against backpressure and backsiphonage conditions for high hazard/toxic application in accordance with Local Governing Water Utility Code. Used primarily on potable drinking water systems where Local Governing Code mandates protection from non-potable quality water being pumped or siphoned back into the potable water system.

The iron components of the backflow preventer are coated with ArmorTek®, a patented three-part advanced epoxy system engineered to reduce microbial-induced corrosion (MIC) and protect exposed metal substrate. The series features Lead Free construction to comply with low lead installation requirements. The Lead Free Reduced Pressure Zone assemblies shall comply with state codes and standards, where applicable, requiring reduced lead content.

The series include a flood sensor to detect excessive water discharges from the relief valve. The flood sensor relays a signal that triggers a multichannel alert (call, email, text) to notify personnel about potential flooding.

NOTICE

An add-on connection kit is required to activate the flood sensor. Without the connection kit, the flood sensor is a passive component that does not communicate with any other device. (A retrofit sensor connection kit is also available for existing installations. For more information, download RP/IS-F-860RP/RPDA.)

NOTICE

Use of the flood sensor does not replace the need to comply with all required instructions, codes, and regulations related to installation, operation, and maintenance of this product, including the need to provide proper drainage in the event of a discharge.

Watts® is not responsible for the failure of alerts due to connectivity issues, power outages, or improper installation.

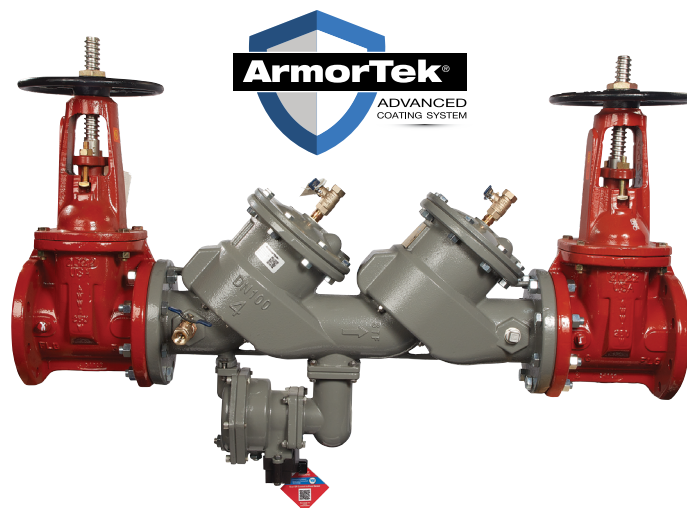

LF860-OSY with flood sensor

Features

- Stainless steel relief valve seat and stainless steel check components for maximum performance and durability
- Inline serviceable assembly; no special tools required
- Captured modular spring assembly
- Reversible and replaceable discs
- Field replaceable seats
- Ductile iron valve body design
- ArmorTek coating technology to resist corrosion of internals
- Modular and repairable pressure differential relief valve
- Clapper check assembly
- Captured O-ring design
- Sensor on relief valve for flood detection, activated by add-on connection kit for BMS or cellular network communication

NOTICE

The information contained herein is not intended to replace the full product installation and safety information available or the experience of a trained product installer. You are required to thoroughly read all installation instructions and product safety information before beginning the installation of this product. Inquire with governing authorities for local installation requirements.

*The wetted surface of this product contacted by consumable water contains less than 0.25% of lead by weight.

Specification

FEBCO MasterSeries LF860 Reduced Pressure Zone assembly shall be installed on the potable water supply and at each point of cross-connection to protect against possible backpressure and backsiphonage conditions for high hazard/toxic applications. The assembly shall consist of a main line valve body composed of a pressure differential relief valve located in a zone between two (2) independently acting approved clapper style check modules with replaceable seats and disc rubbers. Servicing of the pressure differential relief valve and both check modules does not require any special tools; both check modules are accessed through independently top entry covers. This assembly shall be fitted with AWWA Compliant inlet/outlet resilient seated shutoff valves; when used on a Fire-Sprinkler application, the assembly shall be fitted with UL Classified and FM Approved inlet/outlet resilient seated shutoff valves and contain four (4) properly located resilient seated test cocks as specified by AWWA Standard C511. Iron components of the backflow preventer shall incorporate ArmorTek coating technology, delivering integrated protection against electrochemical corrosion and microbial-induced growth. Flow and pressure loss performance parameters shall meet the requirements of AWWA Standard C511. The assembly shall be FEBCO MasterSeries LF860 and shall include a sensor on the relief valve for flood detection.

Model/Option

FS	Sensor on the relief valve for flood detection
OSY	UL Classified and FM Approved OS&Y gate valves (ANSI/AWWA C515 Compliant)
NRS	Non-rising stem gate valves (ANSI/AWWA C509 Compliant)
LG	Less shutoff valves (This is NOT an APPROVED ASSEMBLY.)

Example Ordering Descriptions

4" LF860-OSY-FS - Valve assembly fitted with OS&Y shutoff valves and flood sensor

4" LF860-NRS-FS - Valve assembly fitted with NRS shutoff valves and flood sensor

Approvals - Standards

- Approved by the Foundation for Cross-Connection Control and Hydraulic Research at The University of Southern California (FCCCHR-USC)
- ASSE 1013 Listed
- UL Classified** (US & Canada)
- FM Approved**
- IAPMO
- AWWA Standard C511 Compliant
- End Connections: Compliant to ASME B16.1 Class 125 & AWWA Class D Flange



Assembly Flow Orientation

Horizontal (2½" – 10") - Approved by FCCCHR-USC, ASSE, cULus, FM, IAPMO, and CSA

**Assembly configured with UL Classified and FM Approved OS&Y RW gate valves. Less gate valve assemblies are not UL Classified and FM Approved configurations.

Materials

Main Valve Body	Ductile iron Grade 65-45-12
Relief Valve Body	Ductile iron Grade 65-45-12
Coating	ArmorTek powder coating, applied to internal and external surfaces
Shutoff Valves	NRS resilient wedge gate valve AWWA C509 (Standard) OSY resilient wedge gate valve AWWA C515 (UL Classified and FM Approved)
Check Seats	Stainless steel
Relief Valve Seat	Stainless steel
Disc Holder	Stainless steel
Elastomer Disc	Silicone
Spring	Stainless steel
Clamp	AWWA C606 (10" only)

Pressure - Temperature

Max. Working Pressure	175 psi (12.1 bar)
Min. Working Pressure	20 psi (1.4 bar)
Hydrostatic Test Pressure	350 psi (24.1 bar)
Hydrostatic Safety Pressure	700 psi (48.3 bar)
Temperature Range	33°F – 140°F (0.5°C – 60°C) continuous

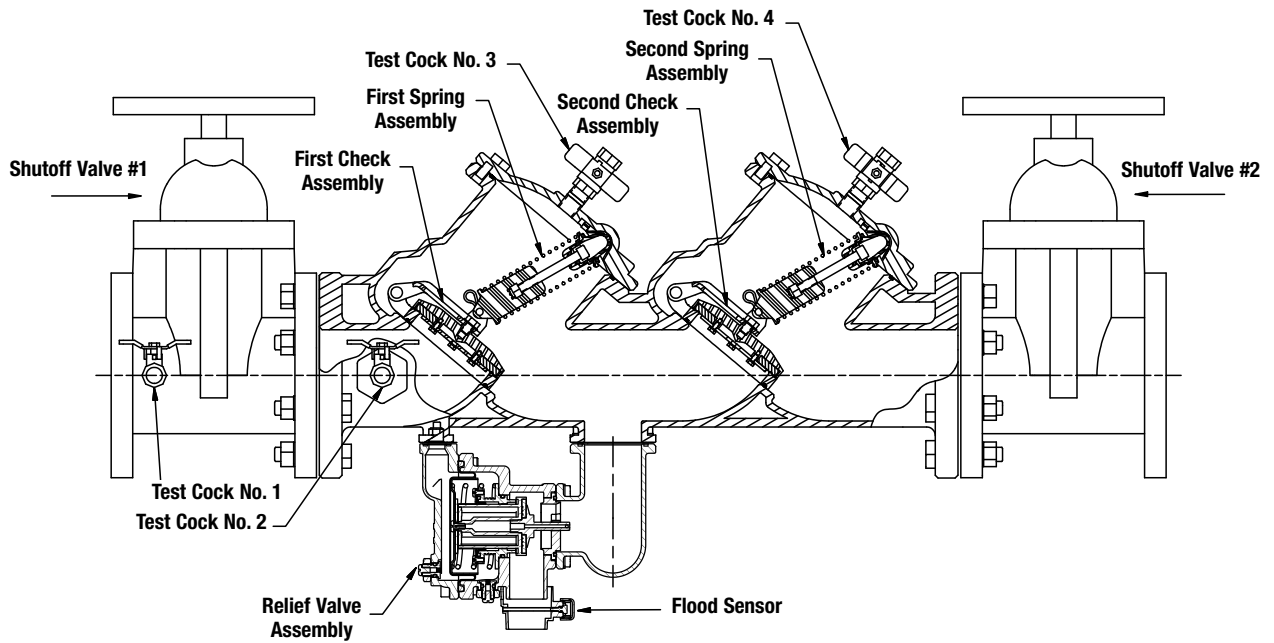

Dimensions and Weights

Below are the nominal dimensions and physical weights for LF860, sizes 2½" to 10". Allowances must be made for normal manufacturing tolerances. Download installation instructions at Watts.com, or contact your local FEBCO representative for more information.

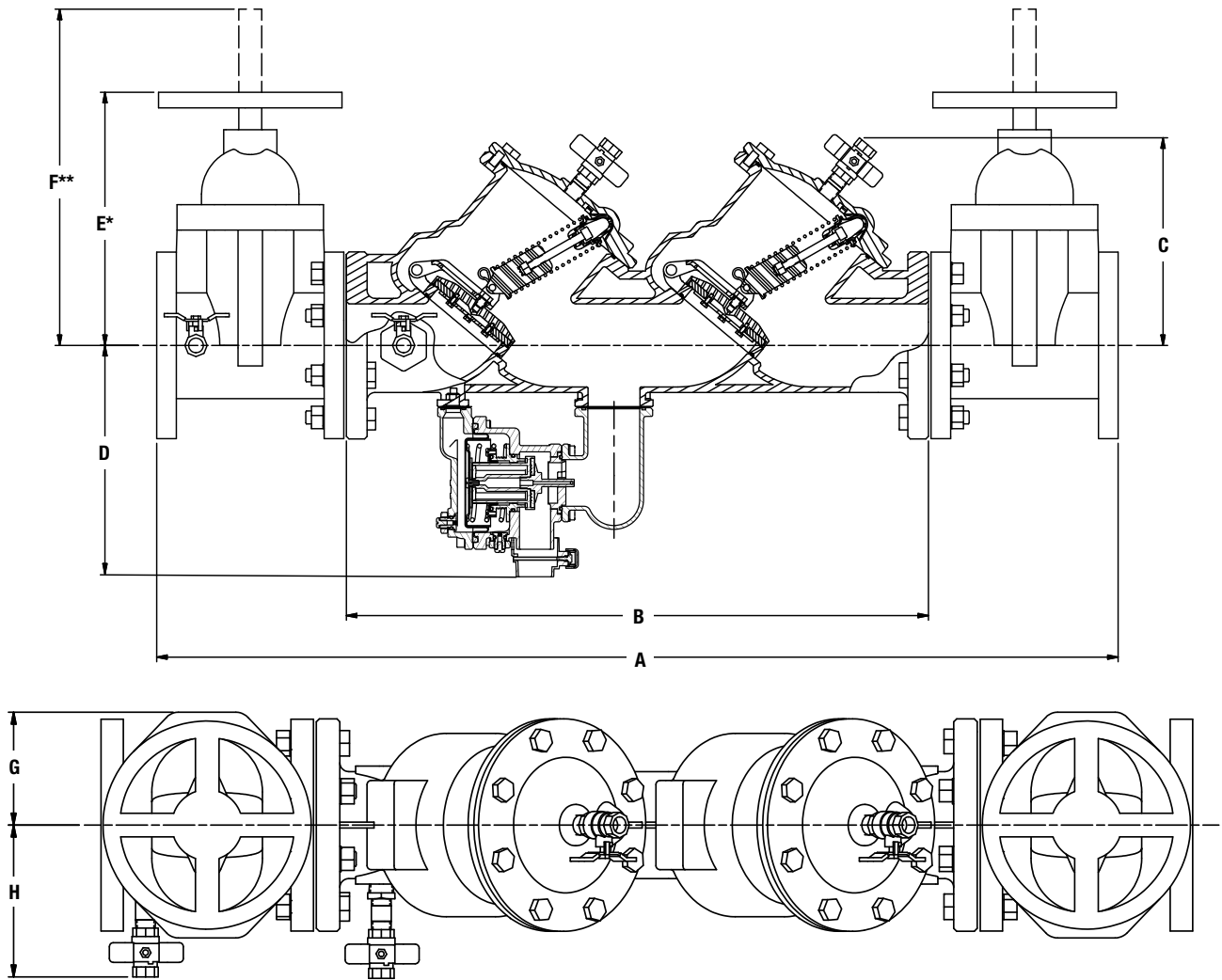

Call customer service if you need assistance with technical details.

SIZE	DIMENSIONS																WEIGHT***			
	A		B		C		D		E*		F**		G		H		NRS		OSY	
in.	in.	mm	in.	mm	in.	mm	in.	mm	in.	mm	in.	mm	in.	mm	in.	mm	lb	kg	lb	kg
2½	40¾	1035	25½	648	10	254	11⅞	288	12⅝	321	16⅜	416	4½	114	7⅞	181	250	113	254	115
3	41⅞	1064	25⅝	651	10	254	11⅜	288	12⅞	327	22¼	565	4½	114	7⅞	187	276	125	280	127
4	46¼	1175	28	711	10½	257	11½	291	14⅜	365	23¼	591	5½	140	8⅞	206	335	152	347	157
6	56	1422	34¾	883	12¼	324	12½	316	18⅞	479	30⅞	765	6½	165	9⅞	251	503	228	523	237
8	65	1651	41¾	1061	15⅝	397	13⅝	345	23½	597	37¼	959	7	178	11⅞	283	807	366	835	379
10	72⅝	1845	46⅝	1178	15⅝	397	13¾	348	27½	699	48	1219	9	229	12⅝	314	1205	547	1243	564

* Indicates nominal dimensions with NRS gate valves.

** Indicates nominal dimensions with OSY gate valves (full open position).

*** Indicates weight of complete backflow preventer assemblies with specified gate valves.

The gap drain is not designed to catch the maximum discharge possible from the relief valve. The installation of the FEBCO air gap with the drain line terminating above a floor drain handles any normal discharge or nuisance spitting through the relief valve. However, floor drain size may need to be designed to prevent water damage caused by a complete failure condition. Do not reduce the size of the drain line from the air gap fitting.

Performance

The flow capacity chart identifies valve performance based upon rated water velocity up to 20 fps.

- Maximum service flow rate is determined by maximum rated velocity of 7.5 fps.
- AWWA Manual M-22 (Appendix C) recommends that the maximum water velocity in the services be not more than 10 fps.
- UL flow rate is determined by typically rated velocity of fps.

Capacity

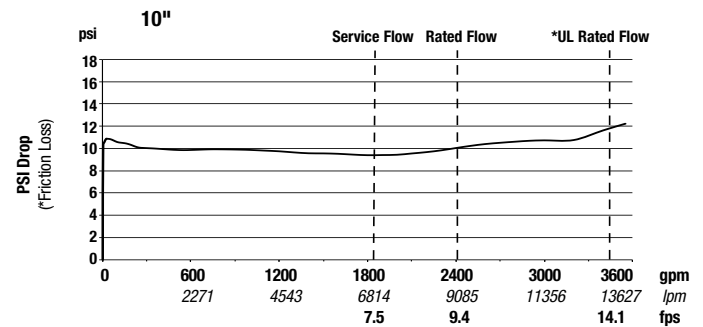
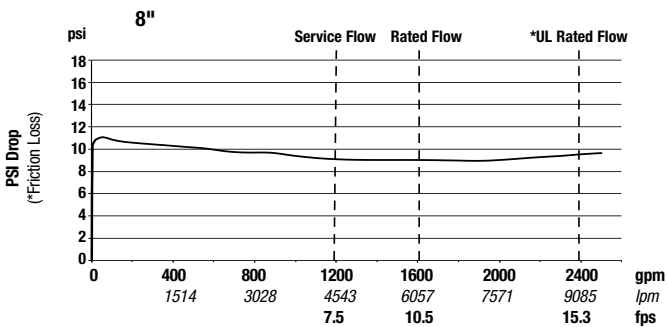
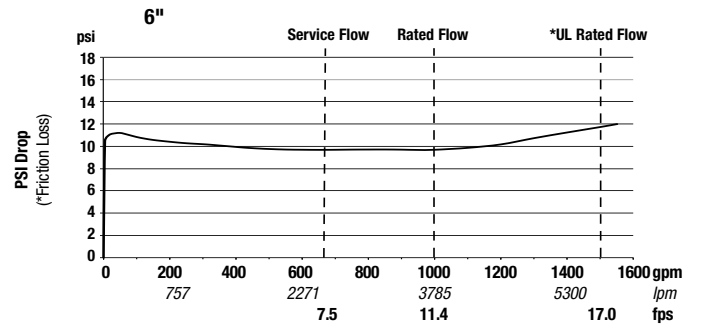
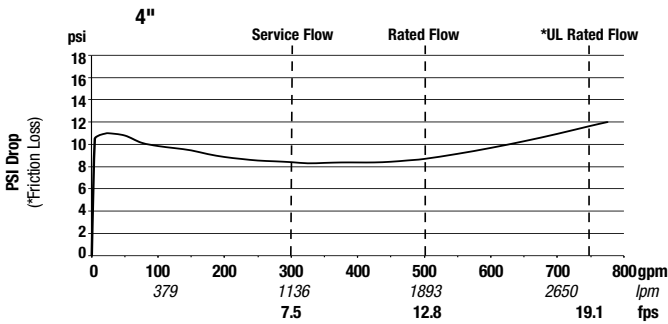
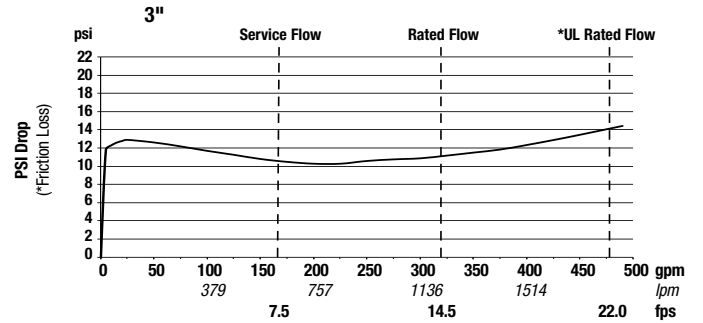
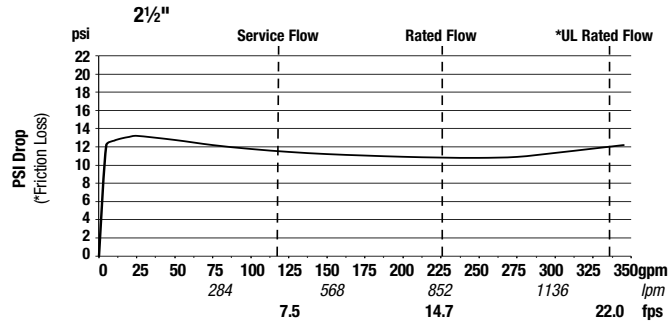

A WATTS Brand

USA: T: (800) 767-1234 • FEBCOonline.com
 Canada: T: (888) 208-8927 • FEBCOonline.ca
 Latin America: T: (52) 55-4122-0138 • FEBCOonline.com

