

Engineering Specification

Job Name _____

Contractor _____

Job Location _____

Approval _____

Engineer _____

Contractor's P.O. No. _____

Approval _____

Representative _____

LEAD FREE*

MasterSeries® LF876W/WZ

Double Check Detector Assembly (Type II)

4" – 10"

FEBCO MasterSeries LF876W/WZ Double Check Detector assembly is specifically designed to provide drop-in replacement of competitor's valves in either the N-pattern (LF870W) or Z-Pattern (LF870WZ) orientation. This assembly protects against possible backpressure and backsiphonage conditions for non-health hazard (pollutant) application in accordance with Local Governing Water Utility Code.

The iron components of the backflow preventer are coated with ArmorTek®, a patented three-part advanced epoxy system engineered to reduce microbial-induced corrosion (MIC) and protect exposed metal substrate. The assembly is primarily used on potable drinking water systems and fire sprinkler systems, where Local Governing Code mandates protection from non-potable quality water being pumped or siphoned back into the potable water system.

Features

Main Valve:

- In-line serviceable assembly
- No special tools required
- Captured modular spring assembly
- Reversible and replaceable discs
- Field replaceable seats
- ArmorTek coating technology to resist corrosion of internals
- Winterization feature with disc retainers and valve body drain ports
- Clapper check assembly
- Commonality between 1st and 2nd check components
- Captured O-ring design

Auxiliary Bypass:

- Compact design; remains in main valve assembly profile
- In-line serviceable ¾" check assembly
- Field replaceable seat and disc
- Detect potential underground water leaks
- Detect unauthorized water usage

*The wetted surface of this product contacted by consumable water contains less than 0.25% of lead by weight.

FEBCO product specifications in U.S. customary units and metric are approximate and are provided for reference only. For precise measurements, please contact FEBCO Technical Service. FEBCO reserves the right to change or modify product design, construction, specifications, or materials without prior notice and without incurring any obligation to make such changes and modifications on FEBCO products previously or subsequently sold.



LF876W

Specification

FEBCO MasterSeries LF876W/WZ Double Check Detector assembly shall be installed on the potable water supply and at each point of cross-connection to protect against possible backpressure and backsiphonage conditions for non-health hazard (pollutant) applications. The assembly shall consist of a main line valve body composed of two (2) independently acting approved clapper style check modules with replaceable seats and disc rubbers. Servicing of both check modules shall not require any special tools and shall be accessed through independent top entry covers. This assembly shall be fitted with approved UL Classified/FM Approved inlet/outlet resilient seated shutoff valves and contain four (4) properly located resilient seated test cocks as specified by AWWA Standard C510. The auxiliary bypass line contains a 5/8"x3/4" Water Meter that complies with ANSI/AWWA Standard C700 coupled with an approved check assembly. The bypass line shall be designed to detect leaks or unauthorized water usage of the water system while protecting against possible backpressure and backsiphonage conditions for non-health hazard (pollutant) application. Iron components of the backflow preventer shall incorporate ArmorTek coating technology, delivering integrated protection against electrochemical corrosion and microbial-induced corrosion. The assembly shall be approved for horizontal and/or vertical-up installations while meeting the requirements of AWWA Standard C510 flow and pressure loss performance parameters. The assembly shall be FEBCO MasterSeries LF876W/WZ.

NOTICE

The information contained herein is not intended to replace the full product installation and safety information available or the experience of a trained product installer. You are required to thoroughly read all installation instructions and product safety information before beginning the installation of this product.

Inquire with governing authorities for local installation requirements.



A WATTS Brand

Model/Option

- OSY: UL Classified/FM Approved OS&Y Gate Valves (ANSI/AWWA C515 Compliant)
- CFM: Totalizing Cubic Feet/Min 5/8"x 3/4" Water Meter (ANSI/AWWA C700 Compliant)
- GPM: Totalizing Gallons/Min 5/8"x 3/4" Water Meter (ANSI/AWWA C700 Compliant)
- LG: Less Shutoff Valves; NOT an approved assembly

Example Ordering Description

- 4" LF876W-OSY-GPM - Valve Assembly fitted with OS&Y Shutoff Valves & Gallons per Minute Water Meter
- 4" LF876WZ-OSY-CFM - Valve Assembly fitted with OS&Y Shutoff Valves & Cubic Feet per Minute Water Meter

Available Components

- Wye Strainer: FDA Approved (ASME B16.1 Class 125 & AWWA Class D Flange)

Materials

- Main Valve Body: Ductile iron Grade 65-45-12
- Coating: ArmorTek powder coating, applied to internal and external surfaces
- Shutoff Valves: OSY resilient wedge gate valve AWWA C515 (UL Classified/FM Approved)
- Check Seats: Stainless steel
- Disc Holder: Stainless steel
- Elastomer Disc: Silicone
- Spring: Stainless steel
- Clamp: AWWA C606

Approvals – Standards

- Approved by the Foundation for Cross-Connection Control and Hydraulic Research at The University of Southern California (FCCCHR-USC)
- ASSE 1048 Listed
- UL Classified** (U.S. & Canada)
- FM Approved**
- IAPMO/cUPC
- AWWA Standard C510 Compliant
- End Connections: Compliant to ASME B16.1 Class 125 & AWWA Class D Flange

Assembly Flow Orientation

Horizontal (N-Pattern 4" – 10") - Approved by FCCCHR-USC, ASSE, cULus, FM, IAPMO/cUPC

Vertical Up (Z-Pattern 4" – 10") - Approved by FCCCHR-USC, ASSE, cULus, FM, IAPMO/cUPC



Pressure - Temperature

- Max. Working Pressure: 175 psi (12.1 bar)
- Min. Working Pressure: 10 psi (0.7 bar)
- Hydrostatic Test Pressure: 350 psi (24.1 bar)
- Hydrostatic Safety Pressure: 700 psi (48.3 bar)
- Temperature Range: 33°F – 140°F (0.5°C – 60°C) continuous

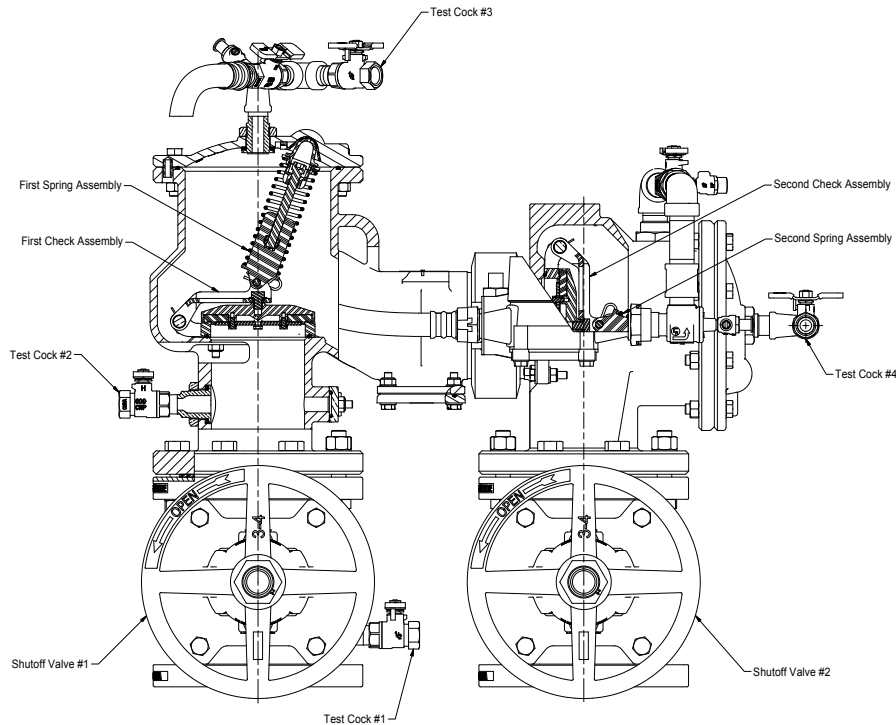

**Assembly configured with UL Classified/FM Approved OS&Y RW Gate Valves. Less gate valve assemblies are not UL Classified/FM Approved configurations.

Dimensions – Weights

Below are the nominal dimensions and physical weights for LF876W, sizes 4" to 10". Allowances must be made for normal manufacturing tolerances. Visit Watts.com to download the product manual, or speak with your local FEBCO representative for more information.

Standard Orientation (N-Pattern)

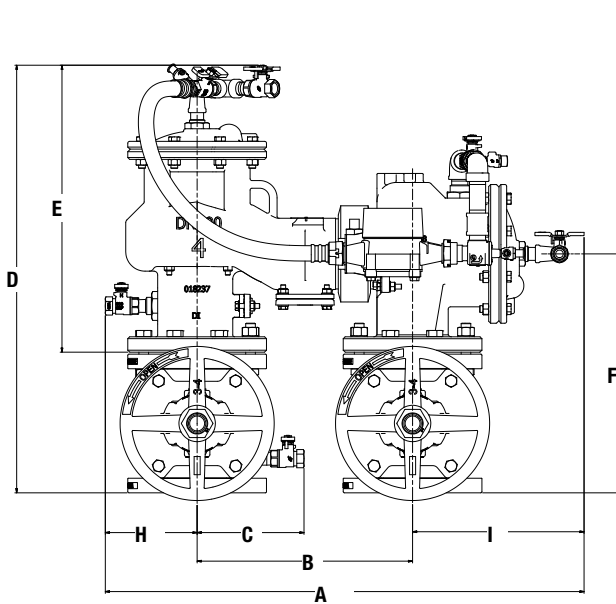

Vertical Orientation (Z-Pattern)

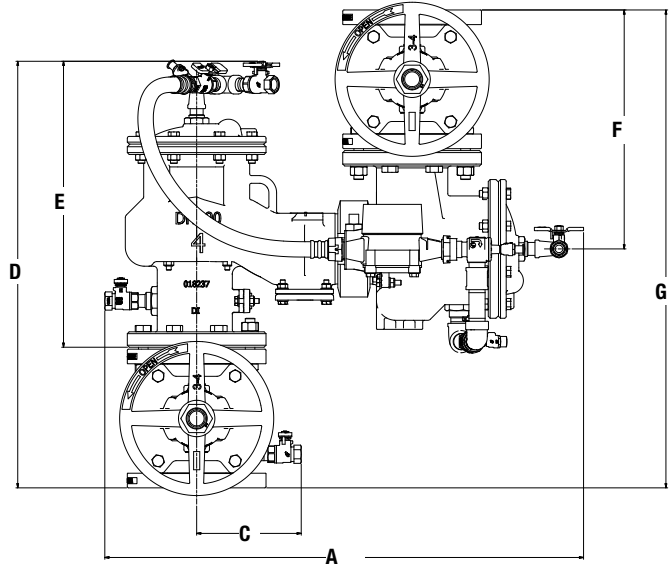

NOTE: The series LF876W/WZ is shipped in the standard (N-pattern) orientation.

Gate Valve Side View Clearance

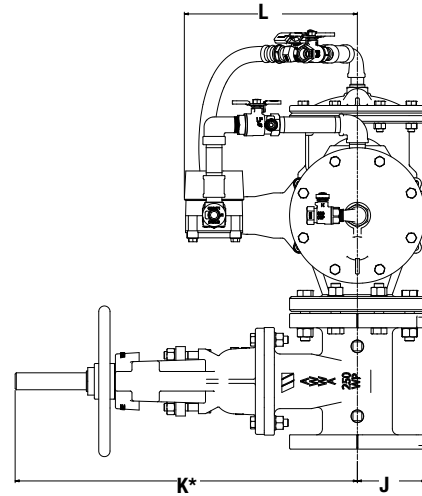

SIZE	DIMENSIONS														WEIGHT**															
	A (W)		A (Z)		B (W)		B (Z)		C		D		E		F		G		H		I		J		K*		L		OSY	
in.	in.	mm	in.	mm	in.	mm	in.	mm	in.	mm	in.	mm	in.	mm	in.	mm	in.	mm	in.	mm	in.	mm	in.	mm	in.	mm	in.	mm	lb	kg
4	32 ³ / ₁₆	818	32 ¹ / ₁₆	833	18 ⁹ / ₁₆	465	18 ¹ / ₁₆	481	7	178	27 ³ / ₄	705	18 ³ / ₄	476	15 ¹ / ₂	394	31	787	6	152	11 ¹ / ₂	283	4 ¹ / ₂	114	23 ³ / ₄	591	13	330	347	157
6	34 ¹ / ₁₆	887	37 ¹ / ₄	946	18 ¹ / ₁₆	475	21	533	8	203	32 ³ / ₄	831	22 ¹ / ₂	562	18 ³ / ₈	473	37 ¹ / ₄	946	7 ¹ / ₄	184	12 ¹ / ₂	316	5 ¹ / ₂	140	30 ³ / ₈	765	13	330	529	240
8	48	1219	49 ⁹ / ₁₆	1253	29	737	30 ³ / ₁₆	770	9 ¹ / ₄	235	36 ³ / ₄	933	25 ¹ / ₂	638	20 ³ / ₄	527	41 ¹ / ₂	1054	8 ¹ / ₂	216	14	356	6 ³ / ₄	172	37 ³ / ₄	959	14 ¹ / ₂	368	827	375
10	50 ¹ / ₁₆	1272	51 ³ / ₈	1304	29	737	30 ³ / ₁₆	533	10 ¹ / ₁₆	264	41 ¹ / ₁₆	1047	28 ¹ / ₂	714	23 ¹ / ₁₆	601	47 ³ / ₈	1202	9 ³ / ₈	244	15 ¹ / ₁₆	398	8	203	45 ³ / ₄	1162	13 ³ / ₈	333	1335	606

* Indicates nominal dimensions with OSY gate valves (full open position).

** Indicates weight of complete backflow assemblies with specified gate valve.

Performance

Flow capacity chart identifies valve performance based upon rated water velocity up to 20 fps.

- Maximum service flow rate is determined by maximum rated velocity of 7.5 fps.
- AWWA Manual M-22 (Appendix C) recommends that the maximum water Velocity in the services be not more than 10 fps.
- UL flow rate is determined by typically rated Velocity of 15 fps.

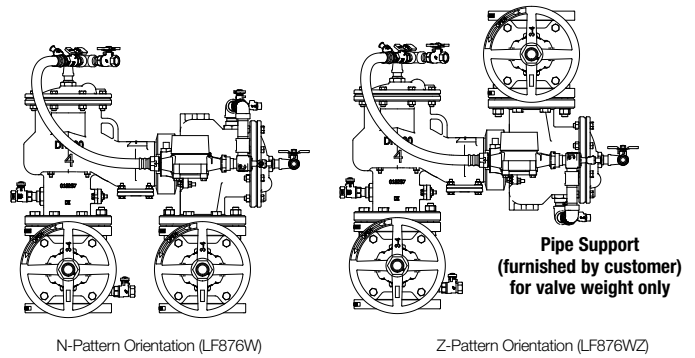

Capacity

N-Pattern Z-Pattern

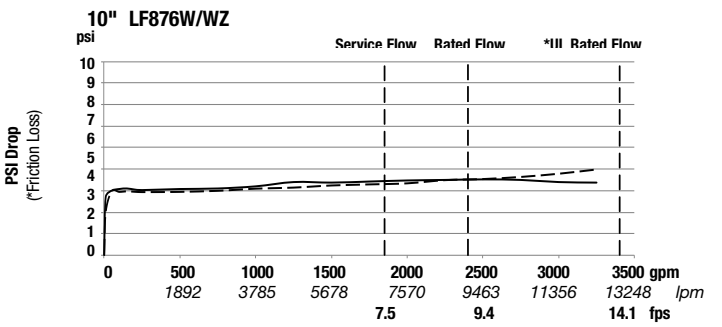
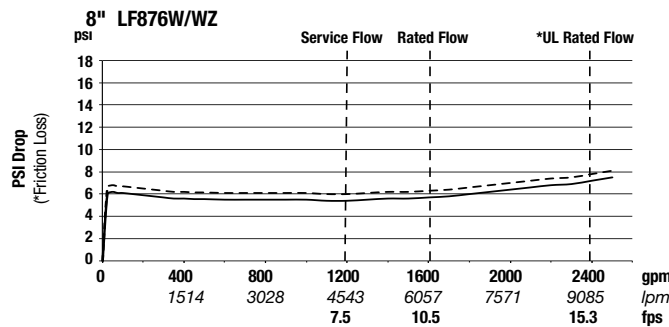
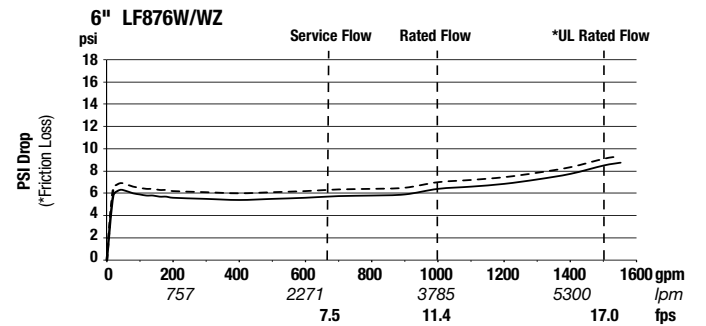
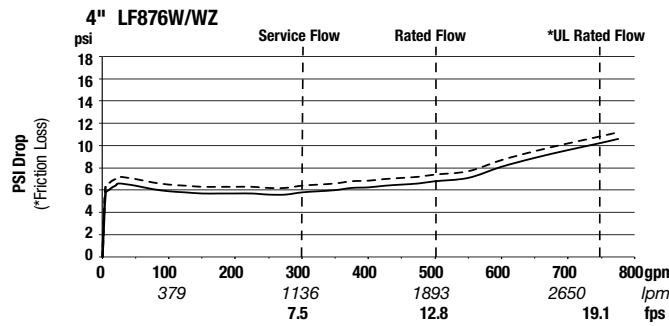
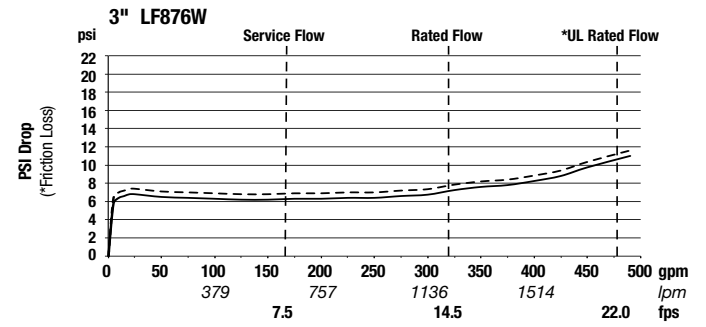
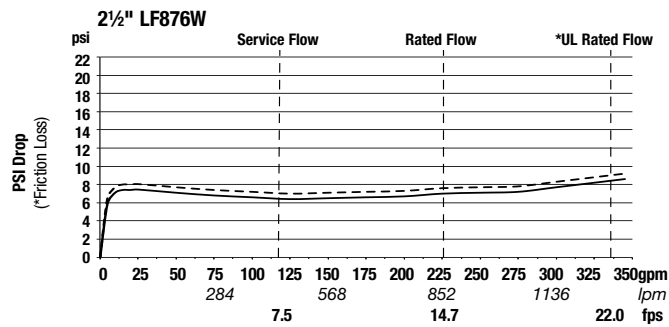

A WATTS Brand

USA: T: (800) 767-1234 • FEBCOonline.com
 Canada: T: (888) 208-8927 • FEBCOonline.ca
 Latin America: T: (52) 55-4122-0138 • FEBCOonline.com